

ZOO REGISTRARS: A BEWILDERING BUREAUCRACY

IRUS BRAVERMAN*

INTRODUCTION

Animals are divided into: (a) belonging to the Emperor, (b) embalmed, (c) tame, (d) sucking pigs, (e) sirens, (f) fabulous, (g) stray dogs, (h) included in the present classification, (i) frenzied, (j) innumerable, (k) drawn with a very fine camelhair brush, (l) *et cetera*, (m) having just broken the water pitcher, (n) that from a long way off look like flies.¹

As a registrar, nobody bothers you. They don't want to know what you do because it will give them a headache. They would rather be out there, getting chased by an animal or getting dirty or bloody or something.

The world and work of zoo registrars is mostly unknown and understudied, even within the registrars' own institutions. Whereas their counterparts in the museum world have received some scholarly attention,³ no scholarly account of zoo registrars has been published

* Irus Braverman, SJD, Associate Professor of Law & Adjunct Professor of Geography, University at Buffalo, the State University of New York. I would like to express my gratitude to each and every zoo registrar interviewed for this project. Special thanks are due to Jean Miller, Judith Block, and Rachél Watkins Rogers—who have spent many long hours explaining their work to me and whose generosity and openness have made this project possible. Many thanks also to Dr. Donna Fernandes, Buffalo Zoo Director, for initially interesting me in this research project and for providing me with constant support along the way. While they can all be blamed for my enthusiasm, the arguments made in this article are solely my own.

1. Jay M. Feinman, *The Jurisprudence of Classification*, 41 STAN. L. REV. 661, 662 (1989) (quoting Jorge Luis Borges in MICHEL FOUCAULT, *THE ORDER OF THINGS* xv (Pantheon 1970) (1966)).

2. Interview with Rachél Watkins Rogers, Registrar, Zoo Miami, in Islamorada, Florida Keys, Fla. (Aug. 6, 2009).

3. See, e.g., *REINVENTING THE MUSEUM: HISTORICAL AND CONTEMPORARY PERSPECTIVES ON THE PARADIGM SHIFT* (Gail Anderson ed., 2004); *REGISTRARS ON RECORDS: ESSAYS ON MUSEUM COLLECTION MANAGEMENT* (Mary Case ed., 1988); JOHN E. SIMMONS, *THINGS GREAT AND SMALL: COLLECTIONS MANAGEMENT POLICIES* (2006);

to date. This may not be too surprising, as the literature on zoos has more dramatic topics to focus on, such as the future survival of wild animals and the ongoing political conflicts between zoo professionals and animal rights activists.⁴ In addition, the work of zoo registrars is not as exotic or romantic as that of animal keepers, who interact with the animals on a daily basis. Zoo registrars, by contrast, are administrators. They sit behind desks, input figures into computers, fill out forms, and attend meetings.

If the zoo is a place of spectacular exhibits,⁵ the work of zoo registrars is precisely its opposite: an administrative routine that is carried out behind the scenes, without the thrill and excitement of the zoo's nature shows. No wonder that of the 175 million visitors who flock to American zoos annually, probably only a handful know the registrar position at the zoo even exists, not to mention the various administrative tasks that this person performs.

So why bother studying zoo registrars? Surprised to be in the spotlight, even some of the registrars interviewed for this project have wondered about my choice. I would suggest that studying zoo registrars and their work is important for precisely the same reasons that make them invisible to the eyes of the public. Specifically, in the (contained) wildness of the zoo, the registrar performs the role of enforcing law and order. She manages the administrative side of the zoo—a junction between database system management and legal administration. The administrative, procedural, and legal aspects of zoo management, despite being so fundamental in contemporary zoos, have all been strikingly neglected in zoo literature.⁶

Registrars are also an apt topic of scholarly study because they both depict and represent a set of significant transformations that have occurred in American zoos over the last few decades. Such transformations include the zoo's dramatic shift from a 19th century

STEPHEN E. WEIL, *MAKING MUSEUMS MATTER* (2002); STEPHEN E. WEIL, *RETHINKING THE MUSEUM AND OTHER MEDITATIONS* (1990).

4. See, e.g., ERIC BARATAY & ELISABETH HARDOUIN-FUGIER, *ZOO: A HISTORY OF ZOOLOGICAL GARDENS IN THE WEST* (Oliver Welsh trans., 2002); JESSE DONAHUE & ERIC TRUMP, *THE POLITICS OF ZOOS: EXOTIC ANIMALS AND THEIR PROTECTORS* (2006); RANDY MALAMUD, *READING ZOOS: REPRESENTATIONS OF ANIMALS IN CAPTIVITY* (1998); ROBERT MULLAN & GARRY MARVIN, *ZOO CULTURE* (1999); COLIN TUDGE, *LAST ANIMALS AT THE ZOO: HOW MASS EXTINCTION CAN BE STOPPED* (1992).

5. See Irus Braverman, *Looking at Zoos*, J. CULTURAL STUD. (forthcoming 2011); JOHN BERGER, *Why Look at Animals?*, in *ABOUT LOOKING* 1, 23 (John Berger, ed., 1980).

6. See also Irus Braverman, *The Institution of Captivity: Governing Zoo Animals in North America* 1–6 (Mar. 16, 2011) (unpublished manuscript) (on file with the DUKE ENVTL. L. & POL'Y F.) [hereinafter Braverman, *The Institution of Captivity*].

colonial institution exhibiting exotic animals for the entertainment of the local urban public to a global conservation enterprise, with corresponding visibility as public institutions and increasing legalization of zoo practices.⁷ The institutional changes that American zoos have undergone have created the two-pronged work of registrars: record keeping and database management, on the one hand, and legal administration on the other. A focus on this double mission of registrars enables this article to trace the shifting mission and practices of zoos.

Lastly, the work of the registrar is uniquely situated on the border between the inside and outside of the zoo. The registrar sets up the official and legal connections between her own zoo and others, and between the zoo's animals and the law. At the same time, the registrar is situated at the heart of what is perhaps the most ambitious and compelling project of contemporary zoos: the project of "dataveillance"—a detailed form of surveillance established through the collection, maintenance, and management of data.⁸ Despite their broad definition of surveillance as involving "the collection and analysis of information about populations in order to govern their activities,"⁹ scholarly endeavors on this topic tend to limit the prospect of surveillance to human subjects. Conversely, this article contends that the project of animal surveillance, and in particular the surveillance systems applied to certain zoo animals, can provide significant lessons about the project of surveillance, the legal and human urge for classification, the use of nonhumans as proxies, and the acute desire to control otherness, all of which are embedded in every human project of surveillance. It will soon become clear that zoo animals are currently subject to an elaborate and uncontested system of surveillance.

This article is structured around the twofold responsibilities of the registrar: record keeping and legal administration. The registrar's first major responsibility is described here based on the ordered series of operations performed by zoo registrars: naming, identifying, recording, and tracking zoo animals. The registrar's second major task, legal administration, is depicted through her role in the transfer

7. DONAHUE & TRUMP, *supra* note 4, at 6–8.

8. See Roger A. Clarke, *Information Technology and Dataveillance*, 31 COMM. ACM 498, 499 (1988).

9. Kevin D. Haggerty & Richard V. Ericson, *The New Politics of Surveillance and Visibility*, in THE NEW POLITICS OF SURVEILLANCE AND VISIBILITY 3, 3 (Kevin D. Haggerty & Richard V. Ericson eds., 2006).

of captive animals from one zoo to another, as required by the Association of Zoos and Aquariums' (AZA's) increasingly influential animal management and breeding programs.

The article argues that these two arms of the registrar's work are inherently interconnected and that this interconnection is based on the substantial ties between scientific and legal discourses, which underlie both the work of classification via information systems and the practice of classification in law. At the heart of these two classificatory systems lie both a powerful human urge for order and a strong assumption that the world *can* be neatly and exhaustively ordered through classification. In the context of zoos, this urge for order is embodied in the position of registrar, which has become increasingly important because of the parallel mushrooming of animal management and breeding programs and the global database system for managing zoo animal information.

This article is a work of legal ethnography.¹⁰ Specifically, the article draws on a series of a dozen semi-structured, in-depth interviews conducted between May 2009 and January 2010 with some of the most prominent zoo registrars in North America that provide a unique perspective on the evolving world of zoos.

I. THE REGISTRAR AS RECORD KEEPER

I'm a papergirl, absolutely.

- Andrea Drost, Curatorial Assistant, Toronto Zoo¹¹

Institutional Background

The zoo registrar is a relatively new position in American zoos. This section explores some of the reasons underlying the emergence of this position and situates this emergence in the recent institutional evolution of American zoos. Judith Block worked in various roles at the Smithsonian National Zoological Park, commonly known as the National Zoo, for over forty years. According to her account, she

10. For a detailed explanation of my use of this term, see Irus Braverman, "The Tree is the Enemy Soldier": The Sociolegal Making of War Landscapes in Israel's West Bank, 42 LAW & SOC'Y REV. 449, 453-54 (2008).

11. Interview with Andrea Drost, Curatorial Assistant, Toronto Zoo, in Toronto, Ont., Can. (June 16, 2009). As Curatorial Assistant, Drost is responsible for all animal shipments.

invented the position of a registrar in this zoo during the 1970s.¹² Based on her long experience with record keeping, Block reflects on the changes that American zoos have undergone since the 1970s. She says that in the past, records were kept "by accident" and only "for certain purposes." For example, many years ago, one curator substituted the record of a deceased snake for that of a living specimen in order to establish better longevity records, because longevity was the most important data point for zoo animals at the time.¹³ Nowadays, Block says, this practice would be considered unethical: "What is now the standard is that you report everything because *you need to know*; you need to know your reproductive rates and you can't really look at success without knowing. Nowadays that's just standard."¹⁴

The elaborate system of record keeping produces data that, in turn, yields knowledge. As Block illustrates, "Without keeping records you really don't learn anything about the animals you're taking care of."¹⁵ Indeed, contemporary American zoos "employ a whole cadre of people whose job it is to keep records."¹⁶ Block believes that this shift is a result of increased attention to the public role of zoos. In her words,

Most zoos are public. . . . [Z]oo animals belong to the zoo but they really don't. . . (in a way that) a great painting doesn't belong to a museum, it belongs to the people. And as part of that trust you need to know the most you can about the animals. . . . [Y]ou must keep records of their breeding, eating, [and of] all the things you would need to know [for improving their] husbandry and management. . . . [It] is an everyday thing. . . . That's the thrust of record keeping.¹⁷

Contemporary record keeping, according to Block, requires focused attention on the minute details of everyday animal behavior. Only this type of detailed recording can produce scientific knowledge about an animal, which, she believes, is part of the responsibility of zoos as public institutions in charge of a common cultural asset. Block's statements embody what is commonly perceived as the

12. Braverman, *The Institution of Captivity*, *supra* note 6, at 112–13 (citing telephone interview with Judith Block, former Registrar for the National Zoo (Sept. 4, 2009)).

13. *Id.* at 113.

14. *Id.*

15. *Id.*

16. *Id.*

17. *Id.*

primary purpose of zoo animal management: the advancement of scientific knowledge in the name of animal species survival.

Block divides record keeping into two distinct categories: inventory-based and husbandry-related.

There's the kind of record keeping that says, "we've got fifteen wildebeests, and this and this wildebeests are the parents of these wildebeests and these three we got from Joe Shmoe." . . . [In this case we ask:] where and when did you get it, what kind of animal is it, how old was it when you got it, and on what terms? These [records] belong to the institution and are accountability records. . . . And then the other kind of record keeping [looks at] . . . how much the [animals] eat and their physical condition. These things are more husbandry-related and the responsibility for that [information] is an overlap between the curators and the keepers. The registrar ends up being the de facto record keeper for both types of records.¹⁸

Record keeping, according to Block, is a complex and fluid process with varying degrees of intensity. On one level, the record contains basic information concerning the names and other identifiers of zoo animals; on a second level, it can document a rich variety of animal behavior. Throughout this process, the registrar is expected to track the source of all recorded information. Finally, the registrar can use the records to track zoo animals through space and time.

A. Naming

Any living thing that has been found, and seen, and identified, has a name.

- Jean Miller, Registrar, Buffalo Zoo¹⁹

Each group can be given a name. With the result that any species, without having to be described, can be designated with the greatest accuracy by means of the names of the different groups in which it is included. . . . In this way, a grid can be laid out over the entire vegetable or animal kingdom.

- Michel Foucault²⁰

It has long been acknowledged in the human context that the governance of large populations requires assigning individuals identifiable names. Naming has been an essential component of the

18. *Id.*

19. Interview with Jean Miller, Registrar, Buffalo Zoo, in Buffalo, N.Y. (June 15, 2009).

20. FOUCAULT, *supra* note 1, at 141.

state's modern project of population governance.²¹ Historically, the requirement for first and family names originated as a prerequisite for the execution and expansion of the modern tax system.²² More recently, the process of naming has been the foundation of a much broader and more elaborate assemblage of identification regimes, mainly conducted through the classificatory allocation of numbers. The parallel use of names and corresponding numbers (e.g., social security, date of birth, and credit card numbers) forms the foundation of contemporary human governance.²³

Not unlike humans, animals also have long been subjected to various types of naming. Specifically, certain zoo animals are targeted by as many as four, or even five, different naming systems: pet names, institutional numbers, global accession numbers, scientific, and, at times, common names. These names are intended for different purposes, operate on a variety of scales, and offer distinct types of information about the animal. Registrar Jean Miller of the Buffalo Zoo describes the historical evolution of animal classification through naming systems. According to Miller, "the gorillas, the elephants, the rhinos, the giraffes—these very public tigers and lions—they got [pet] names because the public could relate to it much better."²⁴ Rachél Watkins Rogers, registrar at Zoo Miami, adds, "The public loves it. They want to see Fluffy the tiger. They want to see Jojo the lion."²⁵

Pet names, which sometimes gesture toward an animal's particular physical features or anthropomorphized family relations, express the intimate physical connection between keepers and animals. For example, a new gorilla that arrived at the Buffalo Zoo received the name Aunt Bumpy, "because when she first came in she was just getting over chicken pox so she had bumps all over her face . . . she was the bumpy one."²⁶ Pet naming a zoo animal accentuates the perceived intimacy that the animal shares with its caretakers and the public. In this way, the pet name can be likened to a human nickname, rather than to the more official first and family names given to human newborns. Indeed, animals that are assigned pet names usually belong to species that can respond to their calling,

21. See JAMES C. SCOTT, *SEEING LIKE A STATE* 65 (1998).

22. *Id.*

23. Kevin D. Haggerty & Richard V. Ericson, *The Surveillant Assemblage*, 51 *BRIT. J. SOC.* 605, 616–17 (2000).

24. Interview with Jean Miller, *supra* note 19.

25. Interview with Rachél Watkins Rogers, *supra* note 2.

26. Interview with Jean Miller, *supra* note 19.

seemingly confirming the bond with their human namers. "Using names in this way is [also] a husbandry technique for moving animals without the use of force," clarifies Miller.²⁷ A herd of roan antelope, on the other hand, will probably not be given pet names, because "they don't come when you call their names."²⁸ Despite their pedestrian utility, pet names are usually inadequate for promoting an animal's identification, at least in the contemporary database systems used by zoos.

Accession numbers are an additional naming system applied to zoo animals. Unlike pet names, naming through numbers (or a string of alphanumeric characters) is not an expression of intimate connection, but rather a function of the animal's identification and tracking in the zoo's institutional records. Since the project of record keeping is a relatively recent undertaking by most zoos, so too is the numbering system. According to Miller,

The whole numbering system started probably a hundred years ago. . . . People then were very isolated. Institutions were very isolated. They brought an animal in, and that was it. [But soon], zoos had to have some way of identifying the animal *within their own institution*. . . . If you got a herd of roan antelope . . . they had to have some way of identifying them for the record. For a while, the record was always based on tag number such and such, in the right ear. [But] you ran out of tag numbers, you ran out of colors of tags. So they decided, well, maybe we'll call this number 1 male. And that's the way our system evolved.²⁹

The growing numbers of zoo animals in each zoo institution thus necessitated the move into a different form of identification—identification without intimate connection. Over time, however, the numbering system could no longer be sustained. According to Miller,

We had male number one and female number one. Their first male offspring was male number two, their first female offspring was female number two, on down the line. That was for the gorillas, but you've got the same thing for the roan antelope. . . . So they thought, "ugh, this isn't going to work." . . . [Y]ou've got a piece of paper lying there, "keeper reports that m1 did such and such." [But], which m1 are you talking about?³⁰

Improving the numbering system sometimes entailed adding certain letters to the previous male/female system. The Buffalo Zoo denotes mammals with the letter M, birds with B, reptiles with R,

27. Personal communication with Jean Miller (February 12, 2011).

28. Interview with Jean Miller, *supra* note 19.

29. *Id.*

30. *Id.*

amphibians with A, and invertebrates, fish, and other small vertebrates with C. This improved naming system relies not only on an arbitrary chronological and sequential numbering, but also on a scientific classificatory system that divides animals according to their Linnaean taxonomy into birds, amphibians, reptiles, and so forth. Hence, beyond the purpose of identifying an animal, this type of naming serves to classify the animal, as discussed below in the context of scientific naming. Other institutions employ different approaches to naming, such as strict numerical sequencing.³¹

The recent computerization of zoo animal information has brought about yet another naming system: global accession numbers. Currently, the most important information system for zoo animals worldwide is the International Species Information System (ISIS). Founded in 1974, ISIS contains the "world standard zoological data collection and sharing software, now used by more than 800 institutions in almost 80 countries."³² "Whenever a record is sent to ISIS," Miller explains, "it is composed of two parts: the institution's name and its assigned number, so it will always be identified as Buffalo 123 or Bronx 123."³³ The combination of the two parts makes each of these identifiers unique. The most recent, and perhaps crucial, development in zoo animal database systems is currently being tested. It is called the Zoological Information Management System, or, in short, the ZIMS Project.³⁴ As part of this project, discussed in more detail below, the combined institutional-numeric system of tracking individual animals is being replaced with a global, randomly generated, nine-digit number.³⁵

In addition to pet names and institutional numeric/alphanumeric systems, there is also the scientific (in contrast to the common) naming system. Unlike the naming systems already discussed, this system does not refer to the individual animal but rather to its generic type. Miller explains the purposes behind this system, which she terms Taxonomy and Systematics. In her words,

31. *Id.*

32. *About ISIS*, INT'L SPECIES INFO. SYS., http://www.isis.org/pages/aboutus_overview.aspx (last visited Nov. 11, 2010).

33. Interview with Jean Miller, *supra* note 19. See also in Appendix A (there, Buffalo Zoo's institutional numbers for vampire bats were supplanted by "xxx").

34. See *The ZIMS Application: Community Need Meets State of the Art*, INT'L SPECIES INFO. SYS., <http://www.isis.org/Pages/zims.aspx> (last visited Nov. 11, 2010).

35. Interview with Jean Miller, *supra* note 19.

Taxonomy and Systematics are the systems by which species or types of animals are identified uniformly so that somebody in this zoo can talk to somebody else on the other side of the world. . . . For the cougar, the common name is cougar, catamount, puma, mountain lion, depending on where in the world you are. But if you say *Felis concolor* you know that you're talking about—whatever the common name might be—you know you're talking about the same type of animal.³⁶

Founded in 1895, the International Commission on Zoological Nomenclature (ICZN) is comprised of twenty-eight members from nineteen countries, mainly practicing zoological taxonomists, who are dedicated to achieving "standards, sense, and stability for animal names in science."³⁷ The ICZN is governed by a Constitution and a Code.³⁸ This group decides whether to assign an animal a new scientific name and how to name it. According to Miller,

They consider chromosomes; they consider structure, habits, range. They consider all of those factors in deciding whether or not they are the same or a slightly different animal. It's a way that people can talk about a particular thing without seeing it. If somebody says that they are going to send us *Panther tigris altaica*, that's the Amur, or Siberian tiger, I know what to expect . . . you know exactly in your mind the description of it, you know its size, you know its normal range, [its] gestational period. Those things have all been identified for that particular animal. It's a way to be able to talk and give information that everybody knows, across the globe, across disciplines. So a veterinarian can talk to a behaviorist about a particular species and . . . each one is seeing the same animal in their mind.³⁹

In these few sentences, Miller quite clearly captures what lies at the heart of the modern project of zoo animal governance: that the management of large populations requires being able to know them from afar, without actually seeing them. An important property of scientific naming is thus its abstractness, which results in a heightened capacity for objectification.⁴⁰ The project of scientific naming in the context of zoo animals is, similarly, an elementary condition for the accumulation and exchange of information across space, time, and disciplinary boundaries. These classifications are, then, objects of

36. *Id.*

37. *About the ICZN*, INT'L COMM'N ON ZOOLOGICAL NOMENCLATURE, <http://iczn.org/content/about-iczn> (last visited February 25, 2011).

38. *Id.*

39. *Id.*

40. *See generally* LORRAINE DASTON & PETER GALISON, *OBJECTIVITY* (2007) (asserting that contemporary science conceptualizes and synthesizes natural objects through abstraction).

cooperation across social worlds, or "boundary objects"—objects that are able both to travel across disciplinary boundaries and to maintain some sort of constant identity.⁴¹

While humans have classified, measured, and standardized just about everything—animals, human races, books, taxes, jobs, and diseases⁴²—what underlies the scientific taxonomy utilized in zoos is the assumption that all living species can be compartmentalized into systemic and hierarchical categories. Such categories not only present themselves to be mutually exclusive but also exhaustive, more broadly imagining a system that is consistent and complete.⁴³ In his groundbreaking work on classification, *The Order of Things*, Michel Foucault explores the importance of what he calls "systemic seeing" for enabling a broad based communication: "To observe, then, is to be content with seeing—with seeing a few things systematically. With seeing what, in the rather confused wealth of representation, can be analyzed, recognized by all, and thus given a name that everyone will be able to understand."⁴⁴

The process of scientific naming alienates the observer from the thing observed, making the observed more abstract and less material. In the case of zoo animals, the general human urge for classification serves an even more specific function. In this context, the urge to classify is a way to submit the unknown and threatening properties of the wild beast into an ordering system in which it can constantly be observed, objectified, dematerialized, and, in turn, better contained and controlled.

The classification of zoo animals into particular scientific categories, such as species and types, presents itself as simple and solid.⁴⁵ This, however, is hardly the case. In fact, the definition of species is far from intuitive and is still hotly debated within biology.⁴⁶ Currently, the word "species" has at least two different scientific connotations. "One is a taxonomic unit used in classification, and the other is a conceptual unit that is fundamental to the 'building blocks'

41. GEOFFREY C. BOWKER & SUSAN LEIGH STAR, SORTING THINGS OUT: CLASSIFICATION AND ITS CONSEQUENCES 16 (1999).

42. *Id.* at 17.

43. *Id.* at 10–11. *But see id.* at 45 (commenting on a newspaper article stating that "there's no such thing as a rodent").

44. FOUCAULT, *supra* note 1, at 134.

45. *See* depictions in Appendix A and Figure 1.

46. *See generally* SPECIES: NEW INTERDISCIPLINARY ESSAYS (Robert A. Wilson, ed., 1999).

of natural history."⁴⁷ Whereas the first meaning refers to the taxonomies created by Linnaeus, the second refers to an entity in nature that is the product of evolution.⁴⁸

B. Identification

At the zoo, naming is usually not an end in itself. Rather, it is intrinsically tied to the desire to identify, record, and track zoo animals. For a name to function as an identifier, a link must be made between the written record and the physical animal to which the record applies.

I always tell the story of the time I went over [to] the monkey house and I asked which one was Mom, and one person called her 'Spook,' and the other one called her 'Martha,' and someone else called her something else. . . . They couldn't match up that animal with that record because [the culture] was all verbal. [Indeed, if] you didn't identify the animal with some tag or unique identifier . . . you would lose track of what animal went with which record. . . . You needed to have something that matched the record with the animal.⁴⁹

That the verbal culture did not necessarily align with the recording culture and that keepers were not always internally consistent in their naming practices illustrates the mismatch between keeper culture (contextual, based on personal relationships with the animals) and registrar culture (hierarchical, based on efficiency and accuracy).

In summary, as long as both keepers and animals were relatively stationary, a personalized identification system based on individual relationships and experiences sufficed. Physical identifiers, such as scars or tags, were good enough when identification projects were performed on smaller scales and when zoo professionals were only responsible for keeping track of the unique attributes of the animals in their collection. Yet both pet names and narrow physical identifiers were insufficiently translatable to outside institutions. As part of zoos' recent shift of mission toward global conservation, along with the parallel globalization of animal data systems, zoos needed to establish a steadier link between the written record and the physical animal. Radio frequency identification (RFID)-based microchips—commonly

47. Anna L. George & Richard L. Mayden, *Species Concepts and the Endangered Species Act: How a Valid Biological Definition of Species Enhances the Legal Protection of Biodiversity*, 45 NAT. RESOURCES J. 369, 385 (2005).

48. *Id.*

49. Braverman, *The Institution of Captivity*, *supra* note 6, at 95–96.

used in the pet and museum industries—were introduced at zoos precisely for this purpose.

Miller stresses the importance of microchips, which identify individual animals much like barcodes. "Ear tags can be removed, they can fall out. Sometimes they are too small," she says, but microchips provide more reliable identification.⁵⁰ Hand-sized machines called "readers" display the digits contained in the microchip inserted into the body of the zoo animal. This enables a match between the animal and the records. The chip's number is entered into the record by the institution that inserted it, Miller further explains (see, for example, Buffalo Zoo's transponder ID for common vampire bat in Appendix A). The same chip stays with the animal for as long as it is alive. "You're told not to reuse them [on a different animal] for the reason that this is supposed to be a unique identifier to go with this animal and its records," Miller says. "You don't ever want to risk the chance that transponder such and such that was in a fish is now in a turtle."⁵¹

Despite their reliability, transponders are usually not used in large groups of small animals such as frogs or fish. "You have to remember that this chip costs a dollar or two," Miller explains.⁵² "Plus," she adds, "that keeper or vet [doesn't always have the] time to catch the fish, to handle it properly, and to inject the transponder. You could do that, but we don't, normally."⁵³ An alternative technique for counting large groups, Miller notes, "is to take a photo, blow it up, and then have somebody count the animals."⁵⁴ The identification of such animals takes place on a much larger scale and is mostly concerned with determining their quantity and group patterns rather than their individual identities.

Although seemingly technical, this difference in animal identification methods relays a normative evaluation about which animal is more (and, by extension, which is less) important to humans. Similar to the work of classification itself, the technology through which this classification is performed also distinguishes between animals. Due to their perceived nature, certain animals are identified and recorded individually using advanced forms of

50. Interview with Jean Miller, *supra* note 19 (but see Appendix A for an example of a transponder that was not found).

51. *Id.*

52. *Id.*

53. *Id.*

54. *Id.*

technology (here, RFID), while others (small, numerous, not responding to their calling, or not having identifiable facial features) are identified and recorded only in groups, and, typically, without as much detail. "[I]t is an ethical choice."⁵⁵

I have referred to four distinct methods of naming and to the parallel project of identification that makes naming meaningful on both a material and a temporal scale. To promote accuracy, registrars have been combining several techniques.⁵⁶

Some of the hoof stock have transponders, they have ear tags, they have house names, they have an accession number. They have four pieces of identification on one animal. That's a very valuable thing so you can crosscheck. . . . One is prone to more mistakes if it's only one number or name.⁵⁷

C. Record Keeping

Thus far, I have explored the institutional development of record keeping and the central role of zoo registrars. I will now turn to discuss the process through which the record is formed by the zoo registrar and the type of information that the record includes beyond the animal's name and identification numbers (see, e.g., in Appendix A). According to Rachél Watkins Rogers, registrar for Zoo Miami, the main source of information for animal records is the keepers, since they work with the animals on a daily basis.

The keeper report is the most important thing What keepers capture on a day-to-day basis from the animals that they work with is the basis for all of our knowledge [about animals] in zoos. If the keeper makes a mistake and picks the wrong animal [as] the father or mother, it could . . . genetically ruin a breeding program.⁵⁸

Yet obtaining information from animal keepers can be a complicated process, especially because it requires that keepers write reports. "Zoo keepers are notorious for not . . . writing things down," Rogers explained in her interview.⁵⁹ An additional challenge that registrars face is coordinating the range of professional agendas that must be reflected in the records.

55. BOWKER & STAR, *supra* note 41, at 5.

56. See, e.g., Buffalo Zoo's report on a specific bat in Appendix A, courtesy of Buffalo Zoo.

57. Interview with Jean Miller, *supra* note 19. See Specimen Report in Appendix A for an example of multiple forms of naming. This report lists the bats' taxonomic and common names, their transponder ID's and their institutional names ("xxx").

58. Interview with Rachél Watkins Rogers, *supra* note 2.

59. *Id.*

It's very difficult to get [keepers] to understand [the importance of reporting]. Their focus is the animal. The vets focus on the medicine and medical records, . . . the curators focus on the collection, [and] the director focuses on the zoo. . . . [T]he registrar is the glue in all of that. We grab onto what the curator talks about, we grab onto what the zoo keeper says, we grab onto what the vet says, we grab on to the information in the keeper report and see what really needs to be in there. . . . [We then] either accept it, correct it, or reject it. It's either good enough, [or] it's not right, or it's very important. *You have to assign a value to it. If you don't assign a value to what's put in the record, the records are of no value.*⁶⁰

In other words, even when registrars are provided with accurate information by the various zoo staff, they must still sort through this information to distinguish the valuable from the non-valuable information.

How does the registrar assign value to information so as to decide what to include in the record? At the most basic level, certain information must be included in the record by law. For example, the USDA requires that the movement of every mammal between zoos be recorded. However, in most instances, there is neither hard science nor strict law for the registrar to follow when deciding what information to record and what to leave out. Currently, each zoo maintains its own record system and makes the appropriate decisions internally. Every zoo registrar thus practices broad discretion about what to include in the records.

Nonetheless, certain topics are likely to be included in most zoo records. According to Lynn McDuffie of Disney's Animal Kingdom, it used to be the case that only the birth and death of the animals were recorded, but things have changed significantly since then.⁶¹ At Disney, for example, the staff has agreed to include all "central life events" in the records.⁶² According to McDuffie, in addition to names and identifiers, these consist of information about the animal's acquisition and disposition, as well as the animal's behavioral issues, training, and group composition—"the type of information that will help you manage the animals down the road."⁶³

Whereas all registrars interviewed here agree that information about breeding and rearing should be included in the records as a

60. *Id.* (emphasis added).

61. See Braverman, *The Institution of Captivity*, *supra* note 6, at 117.

62. *Id.*

63. *Id.*

matter of course, the line between valuable and non-valuable information is, nonetheless, not always clear. "The road is not always known in advance," McDuffie acknowledges.⁶⁴ "[Y]ou can't really just be a technocrat," Rogers adds.⁶⁵ "You have to look at the animal's life and choose what needs to be [there]."⁶⁶ While registrars agree that a good animal record must include a wide range of information about the zoo animal, they also agree that a cumbersome record will be as useless as no record at all. Indeed, registrars must strike a fine balance between a record that is too thin and one that contains too much information. Both under- and over-recording can, in other words, interfere with the zoo's management of its animals.

The record is limited not only in scope but also in the time frame it covers, which starts with the birth of an animal and ends in its death. Yet even here the line is not clearly fixed, as the record, in fact, is never hermetically sealed.

When [an animal] dies, that's when the record closes. [But] you can still change the record. . . . Say we have two prehensile tail porcupines out on loan to the same institution. They get them mixed up and say, "Emma died and Adelaide is still alive." Then later on, somebody says, "oh, they have transponders, we should read the transponders," and [they find out that] it was Adelaide that died; Emma is still alive . . . I can resurrect that record. But it takes a lot of finagling. It's a mess when a mistake like that is made.⁶⁷

In addition to the acts of naming, identifying, and documenting information about zoo animals in the record, registrars must also be able to track the animals. Rogers defines tracking as knowing where the information came from, who put it in, and when it was put in.⁶⁸ She explains the importance of this process:

Tracking is the main thing I do with everything. I have to track where pieces of paper go. . . . Every time I put a note in a record, I put my initials next to it. I put the initials next to the person who gave me information because . . . I am accountable for anything that gets put in there.⁶⁹

The registrar's definition of tracking is thus very specific, referring to tracking the human trail of information in each particular

64. *Id.*

65. Interview with Rachél Watkins Rogers, *supra* note 2.

66. *Id.*

67. Interview with Jean Miller, *supra* note 19.

68. Interview with Rachél Watkins Rogers, *supra* note 2.

69. *Id.*

instance to ensure accountability. Indeed, the various registrars interviewed here frequently mention the term accountability. At the same time, the registrars also say that their work is disconnected from much of the other work that goes on at the zoo and, as such, is rarely monitored. Along these lines, registrars point to the solitary nature of their work at zoos, which often makes them feel secluded from the rest of the zoo staff. "I'm my own monitor. I monitor myself because nobody else is monitoring me," says Miller.⁷⁰ At the same time, when something goes wrong with the records, some of the registrars clarify, they are held responsible. The institutional accountability of registrars is strongly tied to their legal roles and responsibilities, a topic further discussed later in the article.

II. GLOBAL DATABASE SYSTEMS: FROM A(RKS) TO Z(IMS)

In light of the immense effort that registrars invest in creating a valuable and accurate record for their animals, one would expect the product to be available beyond their particular institutions, or at least to other zoo officials from around the world. Yet despite all the technological advancements, when an animal moves from one zoo to another, in most cases the only data that is electronically available to the receiving zoo is the animal's basic information recorded by the zoo on the international database system ARKS.

ARKS—Animal Records Keeping System—is the fundamental animal database established by the International Species Information System (ISIS) and a product of collaboration between zoos from around the world. The ARKS database system contains the basic information about an animal: its scientific and common names and identifiers, as well as its sex and dates of birth and death. The zoo can record as little as it wants onto this system, McDuffie of Disney tells me, also stating that there is no way to check the reliability of this information.⁷¹ It is up to the recording zoo, then, to decide whether to make the more expansive institutional record of the animal available to other zoos, and when deciding to do so, the information is usually transmitted through manual—i.e., hand written and not electronic—reports that are shipped together with the transported animal.⁷² Despite its generality, the ARKS database has enabled global public

70. Interview with Jean Miller, *supra* note 19.

71. See Braverman, *The Institution of Captivity*, *supra* note 6, at 117.

72. Interview with Debby Martin, Registrar, Toronto Zoo, in Toronto, Ont., Can. (June 16, 2009).

access to the basic electronic information that exists about zoo animals. Using this system, Miller was able to tell me within seconds how many gorillas, for example, were held at the time in zoos around the world. Scrolling through ARKS, she informed me that there were 369 gorillas in Europe and 330 in the United States; she was also able to read as well as the number of males, females, and births (as partially depicted in Figure 1).⁷³

73. Interview with Jean Miller, *supra* note 19.

Gorilla beringe i graueri
Eastern gorilla

Range: EASTERH CONGO

7 Copyright ISIS 12 Jan 2011

| Institution | Males | Females | Unknowns | Births (last 12 months) |
|---------------------|-------|---------|----------|-------------------------|
| ANTWERP | 0 | 2 | 0 | 0 |
| (Regional Subtotal) | {0} | {2} | {0} | {0} |
| Totals | 0 | 2 | 0 | 0 |

Gorilla gorilla
Western gorilla

Range: SE NIGERIA-CONGO

7 Copyright ISIS 12 Jan 2011

| Institution | Males | Females | Unknowns | Births (last 12 months) |
|---------------------|-------|---------|----------|-------------------------|
| KYIV ZOO | 1 | 0 | 0 | 0 |
| (Regional Subtotal) | {1} | {0} | {0} | {0} |
| Totals | 1 | 0 | 0 | 0 |

Gorilla gorilla gorilla
Western gorilla

Range: CAMEROON, CONGO, GABON

7 Copyright ISIS 12 Jan 2011

| Institution | Males | Females | Unknowns | Births (last 12 months) |
|-------------|-------|---------|----------|-------------------------|
| AL AIN | 0 | 1 | 0 | 0 |
| AMSTERDAM | 3 | 3 | 0 | 0 |
| ANTWERP | 1 | 0 | 0 | 0 |
| APELDOORN | 3 | 7 | 0 | 0 |
| ARNHEM | 3 | 7 | 0 | 0 |
| BARCELONA | 2 | 6 | 0 | 1 |
| BASEL | 2 | 3 | 0 | 0 |
| BEAUVAL | 2 | 7 | 1 | 1 |
| BEKESBIRNE | 16 | 33 | 0 | 1 |

Figure 1: ARKS dataset for Eastern Gorilla and Western Gorilla⁷⁴

In addition to the ARKS animal database, ISIS also coordinates the Medical Animal Records Keeping System (MedARKS) software. This database "supports veterinary medical records keeping and

74. *Isis Species Holdings*, INT'L SPECIES INFO. SYS., <http://www.isis.org/Pages/findanimals.aspx> (last visited Apr. 3, 2011).

collection management," such as clinical pathology, necropsy information, and serum chemistry.⁷⁵ Discussing MedARKS in general, and the disadvantages of its separation from ARKS in particular, Miller explains that ARKS and MedARKS are "two standalone programs" that "don't really talk" to each other because information cannot be imported from one to the other.⁷⁶

Since 2001, zoo professionals from around the globe have collaborated to create a new database program that would overcome the problems of the older and separate ARKS/MedARKS system.⁷⁷ They have come up with ZIMS—the Zoological Information Management System. After extensive delays and institutional changes, the first stage of this new program was finally released for application by 18 zoo institutions in March 2010. According to the revised ISIS website, by the end of 2012 most ISIS members will have made the switch to the ZIMS application.⁷⁸ The project's significance was described by some of the major zoo professionals involved:

Although ISIS is dedicated to serving the zoological community, it is a small, member-owned non-profit organization that has not been able to keep pace with the technological advancements in information management and does not have the resources to ensure the accuracy of the records it receives. . . .

What is needed is the immediate development of a *global animal management database* that is Web-enabled and contains up-to-the-minute information that is *both accurate and secure*. Although the database must be flexible enough to meet specific regional needs, there must still be a central, "core" database that allows free and easy exchange of information between all participants. . . .

Our zoological institutions are very reliant on information to provide adequate animal care and participate in conservation programs. We cannot afford to lose any more time in bringing our information technology and data management practices up to speed. *It is extremely important to the management of our collections that we share data globally and that we have confidence in the quality of the data.*⁷⁹

75. *MedARKS Software*, INT'L SPECIES INFO. SYS., <http://www.isis.org/Pages/medarks.aspx> (last visited Nov. 29, 2010).

76. Interview with Jean Miller, *supra* note 19.

77. *Id.*

78. Michelle Peters, *The Global Conservation Community is Going Online: 18 Prominent Zoos and Aquariums are Leading the Way*, INT'L SPECIES INFO. SYS., Aug. 18, 2010, <http://www.isis.org/pages/RecentNews.aspx>.

79. Sue Dubois, Kevin Johnson & Brady Smith, *The ZIMS Project: Building Better Zoological Information Systems for Zoos and Aquariums*, INT'L ANIMAL DATA INFO. SYS.

This quote highlights both the importance of information for the management of zoo animals as well as the shifting scales of this administrative enterprise. Highly involved in the new software's creation, the registrars interviewed for this project express their enthusiasm about its potential implications, describing ZIMS as transformative to their work, even revolutionary. For example, Rogers of Zoo Miami says about the new software,

I love ZIMS. I can't wait for it to happen. . . . This is the first time in the history of zoos that the system they're using for their records has been collaborated on by zoo people in different disciplines around the world. The researchers, the collection managers, the veterinarians, the keepers, the publicists, the maintenance people—all these different people that work within the zoo.⁸⁰

Rogers continues to explain that ZIMS will be recorded "in real time," by which she means that information will be updated directly, instead of through the zoo's institutional records.⁸¹ This move toward both a direct and a global system of management represents a jump up and expansion, on the spatial scale, as well as a temporal shift to an instantaneous mode of documentation. Here, the expansion of geographies goes hand in hand with a reduction in time.

Another implication of this new process is that that zoos will no longer be required to reenter the animal's entire record into their system every time animals are repositioned. "Right now," Miller says, "when we get an animal in from another institution, we have to reenter the same information. . . . [But] with the ZIMS system, we won't have to do it all [over] again. It will all be there."⁸²

The animal's identity will no longer be created by the registrar at the particular institution and tied to its physical presence there (e.g., "Jojo the lion" or "Buffalo 123"), but will be assigned a fixed global number that will accompany it through the course of its lifetime. "Instead of me creating a new number, it will have its own number," says Miller, adding, "So with ZIMS, I will be able to see all the records that [Philadelphia] approved that we see. These will all be one record so that any records that they keep . . . is now our record. I won't have to copy it again."⁸³

COMM. (2002), http://www.iadisc.org/reports/building_better_info_systems.htm (emphasis added).

80. Interview with Rachél Watkins Rogers, *supra* note 2.

81. *Id.*

82. Interview with Jean Miller, *supra* note 19.

83. *Id.*

While ostensibly technical and insignificant, this change is critical to the globalization of animal bodies. Instead of being tied down to its home institution, the zoo animal will now have an international form of identification; a global paSSPort.⁸⁴ This enhancement in tracking and monitoring animals will enable a much freer movement of animal bodies between zoos. The globalization of records, in other words, is likely to enable the globalization of animals.

ZIMS will also merge together what were previously independent and disconnected databases. "The way the system is now," Rogers reminds us, is "that animal records is one system, the medical records is another system, [and] the studbook records is [yet] another system."⁸⁵ But with ZIMS, "you'll be able to see *all* the systems in *one* record," she explains.⁸⁶ Miller adds that ZIMS will also dictate certain information standards, resulting in a more reliable and ready to use system that does not require major verifications.⁸⁷

Finally, ZIMS will also offer a range of graphic options. "This is the other neat thing about ZIMS," Miller says.⁸⁸ "We will be able to link photographs, digital photographs, and digital x-rays to their master record," she explains, and adds an example to illustrate some of the implications of such graphic alternatives:

Say, you're sending two gorillas, a male and female. You'd be able to access their photos online, and then print them so you'd be able to paste that up for the keepers to be able to recognize those animals. When the medical part of it gets in place, you'll [also] be able to upload, store, and link to sonograms. So when you first see a baby elephant by sonogram, that will be the start of that baby's record. Right now we have to wait for a birth in order to create a record.⁸⁹

The technological advancements of this recording process will again enable an extension on the spatial and temporal scales. Miller anticipates that over 700 zoos worldwide—the majority of world zoos—will participate in this program. All registrars interviewed here agree that by replacing the older, more cumbersome, and less effective database systems, the broad-based collaboration of ZIMS

84. The Species Survival Plan Program, or SSP, is a registered trademark of the Association of Zoos and Aquariums. See *Species Survival Plan Programs*, ASS'N OF ZOOS & AQUARIUMS, <http://www.aza.org/species-survival-plan-program/> (last visited Mar. 19, 2011).

85. Interview with Rachél Watkins Rogers, *supra* note 2.

86. *Id.*

87. Interview with Jean Miller, *supra* note 19.

88. *Id.*

89. *Id.*

will create multiple possibilities for an enhanced management of zoo animals. Similar to the recent developments in human surveillance systems,⁹⁰ the centralized and computerized dataveillance will enable the routine processing and analysis of masses of electronic information, thereby affording a level of management and control of zoo animals that was previously impossible. At the same time, this process might also open up new and more serious prospects of error, as some surveillance scholars have warned in the human context: “Dataveillance relies on conscientious and accurate data input by a widely dispersed and uncoordinated network. . . . Each keystroke contains possibilities of errors, some of which can have monumental consequences.”⁹¹

Most of the registrars interviewed here did not speak directly about the reasons and purposes that underlie the zoos' shift to the improved system of global identification, tracking, and management of zoo animals. Other zoo officials have clarified that these shifts have been carried out, first and foremost, in the name of conservation.⁹² Whereas the more traditional exhibit focus did not require much animal management outside of the gates of the zoo, a broad based conservation ethos entails the mobilization of animals for breeding purposes in an attempt to create an independent zoo animal population that does not rely on takings from the wild. The zoos' shift toward conservation has manifested in an abundance of animal programs established and facilitated by the AZA since the late 1970s that typically focus on breeding a long-term, genetically diverse, and sustainable population of captive animals.⁹³ Typically, these programs are oriented toward securing a particular kind of zoo animal—either threatened or endangered or popular among zoo visitors. This, then, is a selective management project; animals that are not endangered, threatened, or popular are exposed to a weakened form of

90. See SIMSON GARFINKEL, *DATABASE NATION: THE DEATH OF PRIVACY IN THE 21ST CENTURY* 75–84 (2000) (detailing how the development of technologies such as radio frequency identification devices enables mass collection of data); see generally Haggerty & Ericson, *supra* note 9 (describing the proliferation of surveillance activities that are integrated and hidden in everyday life through technology).

91. Haggerty & Ericson, *supra* note 9, at 16–17.

92. See, e.g., interview with William Conway, Director, Bronx Zoo, 1966–1993, in Bronx, N.Y. (July 14, 2009).

93. Personal communication with Jean Miller, *supra* note 27.

management (incidentally, the opposite seems to be true in the human context⁹⁴).

The next section further discusses the hierarchical management of zoo animals based on their "green" value, which forms what may be described as an instance of "green imperialism."⁹⁵

III. SPECIES AND POPULATION MANAGEMENT

In addition to the use of animal records—most prominently, ARKS, MedARKS, and ZIMS—for the individual management of *all* zoo animals, zoo professionals have been utilizing species-based databases for the management of certain zoo animals. The most common database for facilitating conservation-focused breeding in captive populations of sensitive species is the studbook. According to the AZA, a studbook "dynamically documents the pedigree and entire demographic history of each individual in a population of species. These collective histories are known as the population's genetic and demographic identity and are invaluable tools that track and manage each individual cared for by AZA members and affiliates."⁹⁶ The choice of which species to catalogue is typically based on the status and number of these species in the wild.⁹⁷

Studbooks are usually managed on a regional scale (e.g., in the United States) and coordinated by professional volunteers, frequently from the zoo community.⁹⁸ Based on the information recorded in studbooks, 450 corresponding animal programs are currently in operation in the United States.⁹⁹ All AZA-accredited zoos, certified related facilities, and approved non-member participants are required to report the individual animals in their facilities that fall under the

94. For a more elaborate discussion of the differences between zoo animal and human surveillance see Braverman, *The Institution of Captivity*, *supra* note 6.

95. See RICHARD H. GROVE, GREEN IMPERIALISM: COLONIAL EXPANSION, TROPICAL ISLAND EDENS AND THE ORIGINS OF ENVIRONMENTALISM, 1600–1860, at 5–6 (1996) (identifying "green imperialism" as the historic conservation efforts of colonial scientists motivated by a religiously inspired desire to preserve "Eden").

96. *Studbooks*, ASS'N OF ZOOS & AQUARIUMS, <http://www.aza.org/studbooks> (last visited Feb. 15, 2011).

97. See *Species Survival Plan Programs*, ASS'N OF ZOOS & AQUARIUMS, <http://www.aza.org/species-survival-plan-program/> (last visited Mar. 19, 2011) (listing the keeping of studbooks as one of the components of SSP programs for "flagship species" that are threatened or endangered *in situ*).

98. *Id.*

99. For more details about the aims and characteristics of these animal programs see Braverman, *The Institution of Captivity*, *supra* note 6, at 141; *Animal Programs*, ASS'N OF ZOOS & AQUARIUMS, <http://www.aza.org/animal-programs> (last visited Oct. 18, 2010).

scope of these programs and to conform to the recommendations of the specific program coordinator. The flagship of all animal programs in North America is the Species Survival Plan (SSP), which controls and manages the breeding of selected populations from across the country. According to Miller, the SSP records the pedigree of every animal and develops individual breeding plans based on input from geneticists and population managers who calculate the broadest genetic diversity possible to sustain a population.¹⁰⁰ Figure 2 illustrates the complexity of AZA's collective project of managing zoo animals.

While this is not the place to discuss the various ways in which the AZA regulates and enforces its standards and recommendations,¹⁰¹ it is important to emphasize the heightened management implemented through AZA's animal programs, and especially the SSPs. In the United States, what underlies the inclusion of particular species rather than others in many of AZA's animal programs, and in its SSP programs in particular, is their definition as "endangered" or "threatened" species. The origin of these terms in American culture is the legal text of the Endangered Species Act (ESA) of 1973, which established their definitions as a way for classifying animals according to their ecological importance.¹⁰²

If asked to name an "endangered species," typical responses from laypersons would likely include cheetahs, pandas, bald eagles, or other charismatic mammals and birds. Under Section 3 of the ESA, however, "[t]he term 'species' includes any subspecies of fish or wildlife or plants, and any distinct population segment of any species of vertebrate fish or wildlife which interbreeds when mature."¹⁰³ "This definition does not define a species at all; it merely provides for protection of groups below the species level."¹⁰⁴ This indeterminacy could be read as deferring to scientific classifications of species, which assumes that scientists have already figured this out and that there is a solid definition of species out there for the law to rely upon. Yet, species identification is an area of biology that is still quite contentious: for example, there is no single accepted method for

100. Interview with Jean Miller, *supra* note 19.

101. *But see* Braverman, *The Institution of Captivity*, *supra* note 6, at 141–50.

102. *See* 16 U.S.C. §§ 1531–1544 (2006).

103. *Id.* § 1532(16).

104. George & Mayden, *supra* note 47, at 374; *accord* Kevin D. Hill, *The Endangered Species Act: What Do We Mean by Species?*, 20 B.C. ENVTL. AFF. L. REV. 239, 240–43 (1993).

recognizing species.¹⁰⁵ Although the decisions over endangered or threatened status must be made with the "best scientific and commercial data available,"¹⁰⁶ there are no requirements or guidelines for determining if a group of organisms represents a distinct species.

Moreover, while "[t]he ESA makes no value judgments in prioritizing which species should be listed . . . limited knowledge about the earth's biodiversity has resulted in biased listings."¹⁰⁷ This bias exists in the fundamental definition of what a species is and is also reflected in the ambiguity of the definition in the ESA. Specifically, "[o]nly vertebrate groups and some plants are likely to be studied" by scientists.¹⁰⁸ Such deference by law to seemingly objective scientific standards thus obscures the actual problems and biases that lie at the heart of the current scientific system of animal classification. What seems like a technical, objective process is in fact a normative decision made by a network of persons, including the coordinators of animal programs, zoo professionals who work with endangered species, people in the NGO community, and government administrators such as U.S. Fish & Wildlife Service officials.

105. See Jack W. Sites, Jr. & Jonathon C. Marshall, *Delimiting Species: A Renaissance Issue in Systematic Biology*, 18 TRENDS IN ECOLOGY & EVOLUTION 462, 462 (2003); John J. Wiens & Maria R. Servedio, *Species Delimitation in Systematics: Inferring Diagnostic Differences Between Species*, 267 PROC. ROYAL SOC'Y LONDON SERIES B 631, 631 (2000).

106. 16 U.S.C. § 1533(b)(1)(A).

107. George & Mayden, *supra* note 47, at 384.

108. *Id.*

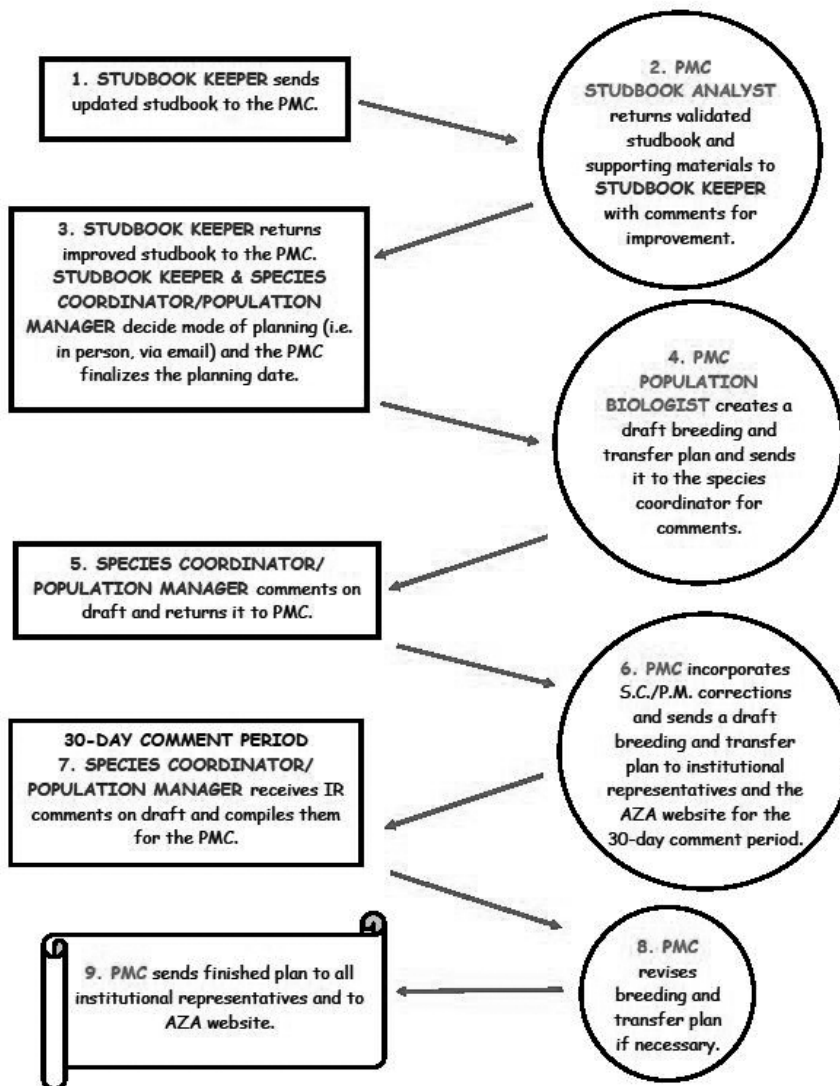

Figure 2: Planning Process Flow Chart¹⁰⁹

109. Ass'n of Zoos & Aquariums, *Population Management Planning Process Flow Chart*, available at http://www.aza.org/uploadedFiles/Animal_Care_and_Management/Animal_Management/Population_Management_Centers/PMC_FlowChart.pdf.

IV. THE REGISTRAR AS THE ZOO'S LEGAL CONSCIENCE

The registrar is the conscience of the zoo.

-Judith Block, Former Registrar, National Zoo¹¹⁰

A. Registrars and Animal Programs

The detailed demographic and genetic management of SSP-type animals translates into a world of institutional, professional, normative, and legal performances that inform the everyday operations of zoos in the United States and around the world. Whereas the registrar is normally not involved in policy decisions about the conservation of endangered and threatened animals, her work is what enables the execution of these decisions. Indeed, the registrar is usually the person at the zoo assigned to manage all acquisitions and dispositions of animals, including negotiating loan agreements and permit applications and coordinating animal shipments between facilities. This project requires a thorough knowledge of and adherence to the complex web of laws that govern the management of animals among zoos.¹¹¹ McDuffie of Disney asserts, accordingly, that through the years she had to learn her way around a shockingly confusing and eclectic regulatory system that included over forty types of permit requirements.¹¹²

Upon its transfer from the zoo on the recommendation of a particular animal program coordinator, an animal is often assigned an "on loan" status (alternatively, the zoo can donate the animal or lend it for exhibit only).¹¹³ Although the animal is physically held by the receiving zoo, it is still owned by the loaning zoo (see, e.g., the breeding loan agreement in Appendix B). Nilda Ferrer, Curator of Animal Management Services at the Bronx Zoo, illustrates how mundane the transportation of zoo animals between American zoos for SSP breeding purposes has become (see, e.g., Figure 3 of rhinoceros in air). In her words, "[w]e just did one yesterday for a red bird of paradise. We imported one from Chile yesterday; we exported one to Chile last week . . . we do a lot of exchanges with other institutions."¹¹⁴

110. Braverman, *The Institution of Captivity*, *supra* note 6, at 112–13.

111. For more details about the legal regimes that apply to zoos see *id.* at 60–85.

112. *Id.* at 122.

113. Interview with Jean Miller, *supra* note 19.

114. Interview with Nilda Ferrer, Curator of Animal Management Services, Bronx Zoo, in New York, N.Y. (July 15, 2009).



Figure 3: Great Indian Rhinoceros in the Air¹¹⁵

When transferring zoo animals—usually in compliance with the recommendations of an animal program—a breeding contract and loan agreement are drafted and signed by the relevant institutions (see, for example, Appendix B). Miller clarifies some of the details of this transaction,

If [the animal] goes out on a breeding loan, normally it will not move unless there's an agreement specifying who is responsible for everything. . . . There's a contract. A written, signed contract. We also have a signed breeding loan separate from the contract. [It] specifies who gets what [offspring and] who is responsible for care. [For example,] in the event that there is a surgical procedure that has to be done, if it's elective, we [as the lending institution] have to approve it. If it's an emergency, it's exempt. We have to be informed within thirty days of the death, [because] we own the carcass. That's all written out beforehand. And sometimes it's very difficult [to negotiate].¹¹⁶

115. Photo of Great Indian Rhinoceros, provided by Andrea Drost, Toronto Zoo.

116. Interview with Jean Miller, *supra* note 19; see Appendix B, general draft of breeding loan agreement, courtesy of Buffalo Zoo.

Andrea Drost of the Toronto Zoo further articulates some of the complexities of such loan agreements:

[I]f we lent out the female, we will get the first female and the second male. The third female will be ours, the fourth male will be ours. So it alternates back and forth between the two sexes and it alternates back and forth between the two zoos. . . . [But] sometimes, instead of being a division of females, it's just a division of viable offspring, so no sex at all. If a turtle lays its eggs and five turtles successfully hatch out, three go to one place, and two go to the other, regardless of sex.¹¹⁷

According to Miller, "[t]he female was always more valuable because she had offspring. . . . [s]o the owner of the female usually got the female offspring." Although this has been the prevailing norm among zoos, Miller believes that it "is going to change in favor of the institution that holds the animal." She further states, "the owner of the female, the owner of the male, these are all terms that [need to be] worked out. . . It's a gamble of ownership."¹¹⁸

Although a crucial part of animal programs, and of the conservation mission of zoos more generally, animal loan exchanges between zoos are also tied to the older, pre-conservationist, zoo model of institutional animal ownership. The breeding loan agreements¹¹⁹ suggest that zoos still seek to gain the greatest institutional advantage from this practice, rather than fully complying with the collective model of zoo animals as cultural commons.¹²⁰

One way or the other, the process of naming, recording, and transferring animals according to calculated genetic and demographic needs leads to the objectification and alienation of those animals; they are perceived as a means to an end, whether the survival of their own species and habitat or, more broadly, the enhancement of scientific knowledge. The laws that pertain to zoo animals and to their transportation between zoos contribute to an objectification and alienation to the animals' already objectified status. These human laws heavily rely on the classification of animals, and, as such, are

117. Interview with Andrea Drost, *supra* note 11.

118. Interview with Jean Miller, *supra* note 19.

119. See Appendix B for an example.

120. See Geordie Duckler, *Towards a More Appropriate Jurisprudence Regarding the Legal Status of Zoos and Zoo Animals*, 3 ANIMAL L. 189, 189 (1997) (citing *Normand v. New Orleans*, 353 So. 2d 1220 (La. 1978)) ("The few tort liability cases directly involving zoos tend to view them as markets rather than preserves; the park animals are viewed as dangerous recreational machinery more akin to roller coasters or Ferris wheels than to living creatures.").

impersonal and rarely take into account the behavior and needs of specific animals.¹²¹

But despite the intensive efforts dedicated to the tighter management of zoo animals, this project is also restricted—at times even managed—by none other than the animal itself. In the end, animals may or may not comply with human wishes. Indeed, to the dismay of many zoo professionals, many animals do not breed well, or do not breed at all, in captivity. Zoos often must resort to a variety of techniques to encourage breeding, such as spraying hormone-containing urine and injecting hormones to increase arousal.¹²² Some zoos in the United States have even trained gorillas to conform to manual sperm collection, which is intended to increase the rate of successful reproduction. This attempt on the part of humans to work around the animals' own agendas, or their "actancy,"¹²³ thus ends up producing yet more sophisticated forms of human–animal management.

B. The Registrar as a Legal Administrator

My previous discussion about the role of registrars in the execution and implementation of animal programs highlighted an important, yet easily overlooked, aspect of the registrar's work—the registrar as a legal administrator. Indeed, on top of their various tasks as the zoo's record keeper, registrars perform the vast majority of the zoo's everyday, petty legal tasks: they identify the relevant city, state, federal, and international laws and regulations that pertain to American zoos as well as the professional standards that apply to them through their membership in the AZA. They also ensure that the zoo complies with these laws, regulations, and professional standards.¹²⁴

As part of the job, the registrar must fill out all permit requests from the myriad agencies that govern and inspect zoos to ensure that the AZA's acquisition and disposition policies are adhered to and that the zoo complies with animal shipment standards. According to Block, "[t]he registrar looks at all the aspects of the transaction," including, checking if permits are in place, whether the person you

121. See Irus Braverman, *The Hidden Zoo: Legal Anomalies and Other Animals*, ENV'T & PLAN. A (forthcoming 2011) (manuscript at 6) (on file with the DUKE ENVTL. L. & POL'Y F.).

122. Braverman, *The Institution of Captivity*, *supra* note 6, at 155.

123. See BRUNO LATOUR, SCIENCE IN ACTION 83–84 (1987) (defining an "actant" as an entity unable to communicate that is represented by a human spokesperson).

124. Braverman, *The Institution of Captivity*, *supra* note 6, at 119.

are getting the animal from is legitimate, if a loan agreement is required and what it would entail, and whether the transaction "fit[s] with the policies of this institution."¹²⁵

Ferrer of the Bronx Zoo emphasizes the importance of law in her everyday work as a registrar,

You need to know all the regulations. You need to know what particular regulations state-wise, city-wise, international, covers the transport of an animal. You need to know when you're transferring something from here to Connecticut, what are the requirements for Connecticut. . . . You need a license to do anything. You need licenses even to transport rodents.¹²⁶

Along the same lines, the registrars interviewed here often mention how difficult it is to stay on top of both the increasing number of and the increasing level of detail in the legal norms and regulations that pertain to the zoos' operations.

Another difficulty with zoo laws is their highly eclectic nature.¹²⁷ Not only do zoo laws differ based on the variety of physical locations that pertain to the specific import or export of animals (e.g., the state and region of the loaning and receiving zoos), but also according to the species involved and the physical structures with which they come into contact. For example, shipping containers must follow a detailed set of instructions that depend on the type of animal shipped (see, e.g., in Appendix C).¹²⁸ In addition, strict quarantine requirements pertain to certain animals, depending both on the species and the locations through which it is transported. Andrea Drost, Curatorial Assistant at the Toronto Zoo, lends her perspective on the complexities of the legal norms that apply to her work.

Not only is [the zoo] very highly regulated but it is [also] species-specific. . . . The regulations will change depending on which animal you're moving and depending on where you're moving it to. . . . [To move a] gorilla from Woodland Park Zoo (from just outside the Seattle area) to here, we needed a CFIA import permit, which had eight pages of regulations and testing [on both ends].¹²⁹

Another source of increasing regulation is the laws that apply to the zoo in its function as a public space. As such, the zoo must comply

125. *Id.* at 120.

126. Interview with Nilda Ferrer, *supra* note 114.

127. Braverman, *The Institution of Captivity*, *supra* note 6, at 138.

128. See, e.g., INT'L AIR TRANSP. ASS'N, LIVE ANIMAL REGULATIONS, CONTAINER REQUIREMENTS 237, 263 (36th ed., 2009) (included in Appendix C).

129. Interview with Andrea Drost, *supra* note 11; see, e.g., INT'L AIR TRANSP. ASS'N, *supra* note 128 (included in Appendix C).

with historic preservation rules, city and state zoning laws, and the Americans with Disabilities Act,¹³⁰ to name just a few relevant legal norms.¹³¹

The registrars are in charge of implementing the routine tasks of small-scale legal administration that have come to dominate almost every aspect of zoo operations. In this sense, they are the zoo's primary legal liaisons. To perform this role, registrars must learn to work with law's reliance on hierarchical classifications;¹³² they must become familiar with the scientific classifications adopted by various laws, such as the distinction between warm- and cold-blooded animals drawn by the Animal Welfare Act¹³³ or that drawn by the African Elephant Conservation Act between African elephants and Asian elephants.¹³⁴

In addition to law's reliance on certain scientific classifications, it also creates its own classification modalities, such as the distinctions between private and public spaces (and the corresponding zoning classifications); between for-profit and non-profit organizations; between federal, state, and city agencies; and between the various forms, permits, and licenses that apply to different types of laws, regulations, and standards. Commonly, the registrar is assigned to deal with the problems and implications of navigating the intricate webs of legal classification.

V. THE REGISTRAR AS CLASSIFIER OF RECORDS AND LAW

This article's initial focus on the registrar's role of record keeping depicted the details of this role and its significance as the major building block for animal databases on various scales. In this context, the article also described the most recent development in captive animal databases—ZIMS. According to the interviewees, this centralized software—created with the active involvement of the registrar community worldwide—is expected to improve communication between zoos and enable tighter management of zoo animals on a global scale. The article then moved to discuss the regional and global management of captive animal *populations*.

130. 42 U.S.C. §§ 12,101–12,213 (2006).

131. See generally Braverman, *The Institution of Captivity*, *supra* note 6.

132. See generally Feinman, *supra* note 1 (discussing the methodology and problems of extensive legal classification); Roscoe Pound, *Classification of Law*, 37 HARV. L. REV. 933 (1924) (discussing the legal preference for detailed classification).

133. 7 U.S.C. §§ 2131–2159 (2006).

134. 16 U.S.C. §§ 4201–4246 (2006).

Unlike the management of individual zoo animals, which applies to all zoo animals, this project typically focuses on endangered and threatened species as well as other charismatic animals. These species are exposed to even more stringent mechanisms of control than those applied to zoo animals in general, including studbooks and animal programs.

Although the registrars commonly construct individual animal records on the institutional level and do not contribute as much to the creation of population management systems, their work is nonetheless highly influential also on the scale of population management. Specifically, the registrar is usually responsible for gathering all the relevant information about an animal and making it easily accessible and intelligible to other zoo professionals. Because information is the centerpiece of the zoos' management regime, their role in collecting, recording, and managing information turns the registrars into important players in the project of collectively managing zoo animals. Finally, this article has explored the role of registrars as legal administrators, examining their work in the execution of the zoo's acquisition and disposition policies and in ensuring compliance with relevant legal requirements.

The affinity of registrars with law goes far beyond their role as appliers and enforcers of zoo laws. In order to understand this affinity, the article now moves to explore the connections between the registrar's two seemingly unrelated functions: registrars as record keepers, on one hand, and their role as legal administrators, on the other hand. A common thread that runs through both functions is the imposition of order. This commonality is at the heart of the registrar's work; although neither a legislator nor a legal practitioner in the common sense of these words, the registrar imposes a similarly formalistic sort of order. Block, of the National Zoo, exemplifies the registrar's fundamental affinity with form and procedure along with the belief that the establishment of such formalistic procedures will facilitate a just end:

I think [you must] have some really good policies in place to protect yourself and to help structure your thinking about these things [T]here should be a consensus and a policy that everyone agrees upon that applies to each case and doesn't differ. . . . And policies [shouldn't be] written off in a corner somewhere, they're usually a collaboration of the administrators and the [b]oard and everybody else. That's the reason [they exist]. . . [a]nd you never know what needs to be in the policy until some situation comes up and you

think "damn, that wasn't covered." And you hash it out and amend the policy.¹³⁵

Block's statement about working through procedures illuminates the registrar's position as the zoo's institutional bureaucrat. Similar to other bureaucrats, zoo registrars operate from the relatively remote location of their offices. According to many of the registrars, this remoteness allows them to remain unbiased and to keep the "big picture" in mind despite the oft-heated debates that ensue among other zoo staff. While curators are motivated primarily by the desire to expand the collection, for example, registrars work on balancing financial and legal factors with the overall plans and policies of the institution.¹³⁶ Based on what she believes is the registrar's non-prejudiced neutrality, Block proposes that "the registrar is the conscience of the zoo."¹³⁷

At the same time, the role of the zoo registrar is not much different from that of a registrar in a museum, and perhaps also not much different from the role of registrars in other major public institutions such as libraries and universities. Specifically, zoos and museums share certain historical affinities that are still embodied both in the terminology and in the organizational structure of these institutions. In zoos, as in museums, one speaks about collections, curators, registrars, and exhibits. Moreover, both institutions rely on the scientific assumption that information is the ultimate means for knowledge and control, and that such information should be gathered through detailed systematic projects of naming, identification, classification, documentation, and tracking. Finally, both museums and zoos share a commitment to public education.¹³⁸

Indeed, zoo registrars often refer to their animals as objects in the zoo's collection and in many ways record them no differently than a museum registrar would a museum's inanimate objects. Block says in comparison that

[a] wildebeest [is not] so unique that it's irreplaceable the way a Rembrandt [painting] would be. This wildebeest is one of a species and has characteristics that will be useful for the population, but it's one of many [and thus] not so special. . . . [However, y]ou can compare [living collections] to a museum collection in that a

135. Braverman, *The Institution of Captivity*, *supra* note 6, at 125.

136. *Id.* at 125–28.

137. *Id.* at 119.

138. *See generally*, SIMMONS, *supra* note 3 (outlining general management policies for registrars and collections departments); REGISTRARS ON RECORDS, *supra* note 3; Braverman, *The Institution of Captivity*, *supra* note 6.

painting needs the right humidity, security, and protection from light . . . [it is] the same with a live animal, you have to make sure that it's . . . safe and has the right temperature and humidity.¹³⁹

Block even goes on to contend that "from the outside . . . [everyone thinks animal collections are] so sexy . . . but I think it's not so important [that animals are alive]." "Anyway," she qualifies, this is "from a registrarial point of view."¹⁴⁰ Some registrars may disagree with Block's museum-oriented interpretation of the zoo's mission and with the possible underscoring of the zoo's uniqueness as an institution that deals with live animals and with conservation that could be implied by this interpretation. Nonetheless, her view serves to highlight the unique perspective that registrars have to offer on the work of the zoo.

The comparison with museum registrars also highlights the intimate connections between the management of information and law enforcement. It has been remarked about museum registrars that, "[a]lthough probably sharing the curator's aesthetic or intellectual passion for the museum's collections, the registrar can never permit feeling to eclipse the pragmatic concerns for documentation . . . the arduous tallying and listing without which collections would be essentially unmanaged and of limited benefit."¹⁴¹

Moreover, museum scholars have pointed to the close affinity between what they call "registrarial thinking" and the worlds of law, order, and logical systems. They have asserted, accordingly, that "[l]egislators, judges, lawyers, and registrars are professional systematizers, organizers, codifiers, and proceduralists."¹⁴² Hence,

[t]he role of registrars—like that of the institutions they serve—is an evolving one. If the last decade has witnessed augmented respect, and understanding of the registrar, it is because our colleagues have increasingly learned to value registrarial orderliness in an environment that is frequently pressurized and occasionally volatile.¹⁴³

Although expressed in the context of the registrar's role in museums, this statement also rings true in the world of zoo registrars.

139. Braverman, *The Institution of Captivity*, *supra* note 6, at 127.

140. *Id.*

141. REGISTRARS ON RECORDS, *supra* note 3, at 133.

142. *Id.*

143. *Id.* at 141.

VI. CONCLUSION

Almost unheard of twenty years ago, the rising importance of the registrar within the American zoo highlights two significant changes that have occurred recently in American zoos. First, it highlights the zoo's transition from an institution dedicated to the entertainment and education of the public into one that focuses more and more on conservation through the management of information. Second, it highlights the increased legalization of zoos. Operating at the junction between these two major changes, the registrar's role in America's contemporary zoos represents and embodies the significance of order in general, and of classification in particular, for the everyday workings of both information and legal systems. This article, in other words, highlights the common urge for classification that underlies both scientific and legal management regimes.

| Report Start Date | Specimen Report for BUFFALO / xxx | | Report End Date | |
|--|--------------------------------------|---|---|--|
| 1/1/1900 | | | 6/4/2008 | |
| Taxonomic name: <i>Desmodus rotundus</i> | | Family: Phyllostomidae | | |
| Common name: Common vampire bat | | Order: Chiroptera | | |
| Current information | | | | |
| Sex: | Female | Sire ID: | UNK at Unknown Location | |
| Birth type: | Captive Born | Dam ID: | UNK at Unknown Location | |
| Birth Location: | X Zoo | Rearing: | Parent | |
| Birthdate-Age: | 1 Jan 1997 - 11Y,5M,2D | Hybrid: | Not a hybrid | |
| <u>Date in</u> | <u>Acquisition - Vendor/local Id</u> | <u>Holder</u> | <u>Disposition - Recipient/local Id</u> | <u>Date out</u> |
| 20 May 2008 | Donation from Y Zoo / 1234 | BUFFALO / xxx | | |
| <u>Date</u> | <u>Identifier type</u> | <u>Identifier</u> | <u>Location</u> | |
| 5 Sep 2002 | Transponder ID | 00-061B-198C | | this transponder was verified on 11 Mar 2004 |
| 24 Jan 2006 | Transponder ID | 081 328 817 | | |
| 24 Jan 2006 | Transponder ID | 00-061B-198C | not found | was not found, so a new transponder was placed |
| <u>Date</u> | <u>Type</u> | <u>Value</u> | <u>Units</u> | |
| 5 Sep 2002 | live animal weight | 25.2 | gram | |
| 11 Mar 2004 | live animal weight | 26 | gram | |
| 24 Feb 2005 | live animal weight | 28.5 | gram | |
| 24 Jan 2006 | live animal weight | | | |
| 16 May 2007 | live animal weight | | | |
| 5 Apr 2008 | live animal weight | | | |
| APPENDIX "A" | | | | |
| BUFFALO ZOO SPECIMEN REPORT | | | | |
| <u>Date</u> | <u>Note type</u> | | | |
| 20 May 2008 | Acquisition note | 2.7 vampires (xxx-xxx) arrived from Y Zoo via American Airlines; 0.0.6 of the bats (xxx-xxx) are identified by Y Zoo transponders and have accompanying specimen reports, but 2.1 could not be identified by ISIS number. The identities of these 2.1 (xxx-xxx) will be determined by process of elimination when their entire colony is caught for vet checkups in the near future, and the specimen #s will be forwarded at that time. Basic information for #s xxx-xxx downloaded from the ISIS website this date. | | |
| 21 May 2008 | Note | bats xxx and xxx were obtained by Y Zoo from the X Zoo on 5 Sep 2002; xxx = X Zoo #xxx, xxx = X Zoo #xxx; since birth location for both is X Zoo, at least the dam must be at X Zoo | | |

APPENDIX B
BREEDING LOAN AGREEMENT
between
the Zoological Society of Buffalo, Inc.
and
«Institution_name», «City», «State»

WHEREAS, the Zoological Society of Buffalo, Inc. (hereinafter called "the Society") and the «Institution_name» (hereinafter called "the Breeder") are both concerned with the preservation and propagation of all animals;

NOW THEREFORE, the parties hereto agree to the terms and conditions set forth below concerning the loan of:

«Sex1» «Species1» Buffalo #«ISIS_No1»
(hereinafter called the "Specimen(s)")

1. Loan—The Society hereby loans the Specimen(s) to the Breeder and the Breeder hereby accepts the loan of the Specimen(s) for the purpose of propagation and exhibition. Exhibition and/or off exhibit holding must be consistent with the best care available at the Breeder's facility, and with a view to protecting the breeding habits of the Specimen(s).

2. Care—The Breeder agrees to provide necessary housing, food and veterinary care to the Specimen(s) and the progeny thereof according to the highest professional standards. The Society agrees that in the event of disease, injury or death of the Specimen(s) or the progeny thereof, the Breeder, and its agents and employees, will be free from all responsibility to the Society for such disease, injury or death; provided, however, that nothing herein shall operate to release the Breeder, and its agents and employees, from responsibility to the Society on account of the negligence of the Breeder, its agents and employees.

3. Report on Death, Disease or Injury—In the event of sickness, injury, or elective veterinary procedures, the Breeder will immediately notify the Director of the Society, and consult with the Society prior to any treatment and procedures, including chemical immobilization or physical restraint (emergency situations are exempt). The Breeder agrees to furnish the Society with a complete written report in the case of death or disease of, or injury to, the

Specimen(s) or the progeny thereof while the Specimen(s) or progeny are at, or being transported to, the Breeder's facility. Such report shall be furnished to the Society within thirty (30) days of the happening of any of the aforesaid events. At the option and expense of the Society, the Breeder shall preserve intact all portions of the carcasses for delivery to the Society.

4. Release—The Breeder shall hold the Society and any of its employees, agents or authorized representatives harmless from any claims arising by reason of anything done or omitted to be done by the Society under or in connection with the execution of this Agreement.

5. Breeding—The Breeder will undertake its best efforts to breed the Specimen(s). Ownership of any viable young produced by such breeding and born either during the term of this Agreement, or within a period after termination of this Agreement equivalent to the normal gestation term of this particular species, will be divided by the Society and the Breeder in the following manner:

The Society will own females 1,3,5, etc. and males 2,4,6, etc. of viable young;

The Breeder will own males 1,3,5, etc. and females 2,4,6, etc. of viable young.

Viable is defined as surviving past thirty (30) days. The Society shall be given first option to obtain any offspring owned by the Breeder that the Breeder declares as surplus.

6. Terms—This Agreement will remain in effect until terminated. Each party hereto reserves the right to terminate this Agreement unilaterally by giving the other party thirty (30) days prior written notice. No specimens or progeny thereof owned by the Society will be transferred from the Breeder's facility unless directed by the Society.

7. Shipping Charges—Transportation charges for shipping the Specimen(s), and the progeny thereof, to either party will be borne by the recipient.

8. Permits and Licenses—The Breeder affirms that the Breeder has all appropriate licenses and permits to possess and hold the specimen(s), and the progeny thereof.

9. Assignment—Neither this Agreement, nor any rights or privileges granted hereunder, shall be assigned without prior written consent by both parties hereto.

10. Annual report—The Breeder hereby agrees to provide the Society with a written report at the end of each calendar year. Such

annual report shall list the number and sexes of viable young produced by breeding and born or hatched during the previous year, together with a list of such young which died during the preceding year.

11. Amendment—This Agreement cannot be modified or amended except pursuant to an instrument in writing signed by each of the parties hereto.

12. Progeny—All terms of this Agreement will apply to progeny owned by the Society for as long as the progeny remain at the Breeder's facility.

President/CEO
Zoological Society of Buffalo, Inc.

(date)_____

Authorized Representative
«Institution_name»

(date)_____

AN. MAN. APPROVAL_____

APPENDIX C IATA CONTAINER REQUIREMENTS



Container Requirements

EXAMPLE

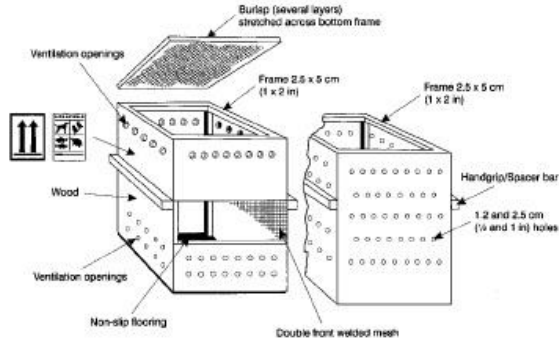

- Notes:**
1. Food and water troughs must be provided for each bird.
 2. Flamingoes must be restricted to 4 birds per crate.

EXAMPLE (shipping container for flamingos)

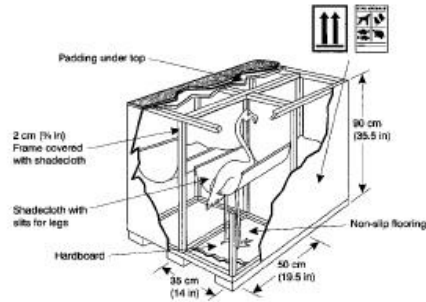

EXAMPLE:

